

Abstract Submission No. : 2333

Feasibility of Immunoabsorption plasmapheresis in an infant for ABO-incompatible solid organ transplant—A reality

Saamil Gaur, Partha Pratim Paul, Mounika Motamarri, Sheikh Rahamatulla
 Department of Pediatric Nephrology, Rainbow Children's Hospital, Bangalore, India

Case Study:

Background: Immunoabsorption (IA) plasmapheresis is standard modality for pre-transplant desensitization in ABO-incompatible solid organ transplants though technically challenging when considered for an infant or a child less than 10 kg due to non-availability of pediatric immunoabsorption (IA) columns. The major challenge is to maintain hemodynamic stability considering the large extracorporeal circuit volume meant for adults. To our best knowledge after extensive search in acclaimed global medical journals, this is the first successful attempt in an underweight (6 kg) infant of less than 1 year of age using adult size IA Column thus making it a reality.

Case characteristics: We report an 8-month-old male infant (A positive) of 6 kg with decompensated liver disease secondary to extrahepatic biliary atresia requiring urgent live donor liver transplantation with AB positive donor with significantly elevated pre-transplant anti-B IgG/ IgM antibody titers >1:1024. Baby underwent multiple sessions of anti-B immunoabsorption plasmapheresis to lower anti-B IgM / IgG titers using available adult anti-B immunoabsorption column. Postprocedure, the antibody titers reduced to 1:8 (anti-IgG) 1:16 (anti-IgM) followed by successful ABO-incompatible live donor liver transplant (LDLT).

Outcome: Anti-B titers remained in normal range in the immediate and post-transplant period with satisfactory liver functions and no rejection.

Conclusion: Immunoabsorption plasmapheresis for ABO-incompatible solid organ transplantation in infants gives desirable results and can be offered to small sized infants using currently available adult sized IA columns when conducted with adequate technical expertise.

Serial fall in anti IgG and IgM titres after each session of Immunoabsorption Plasmapheresis

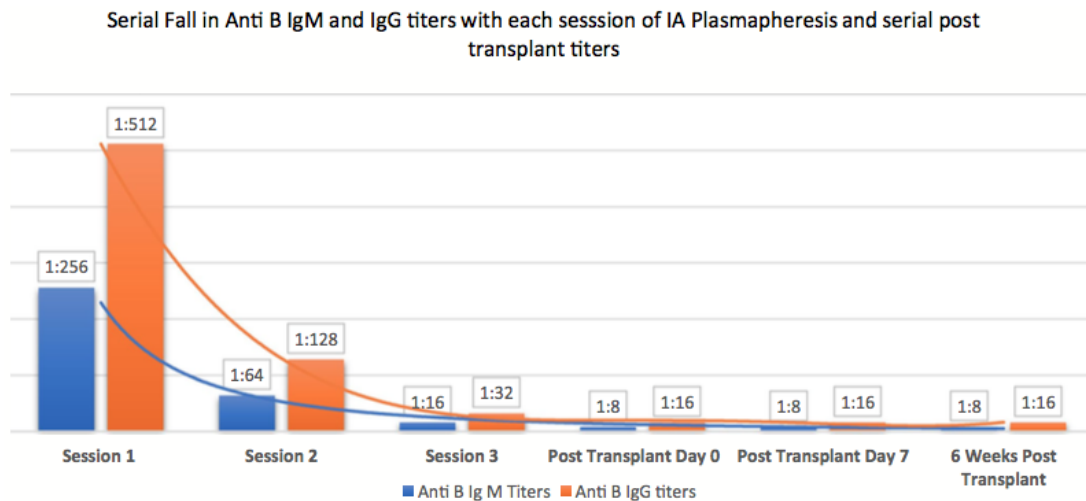
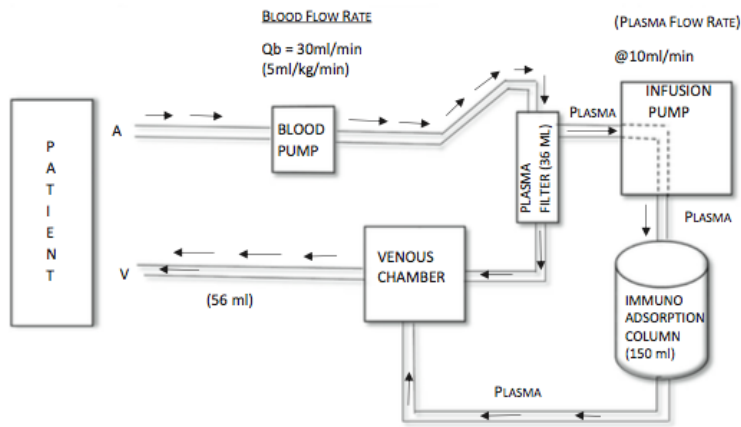

FIGURE 2 Serial fall in anti-B IgM and IgG titers with each session of IA plasmapheresis and serial post-transplant titers

Diagrammatic Representation of Immunoabsorption Plasmapheresis circuit in child with 6 kg weight along with volumes and flow rates

KSN 2021
FULLY VIRTUAL MEETING
September 02 (Thu) - 05 (Sun)



- Total Extra Corporal Volume - 240- 250 ml

FIGURE 1 Diagrammatic representation of the circuit for IA plasmapheresis for the index case of 6 kg